

DIRECTIONAL VALVES

CV08-20 Check Valve

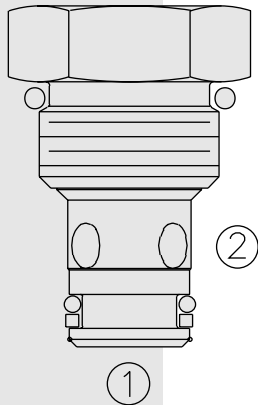

DESCRIPTION

A screw-in, cartridge-style, hydraulic check valve for use as a blocking or load-holding device.

OPERATION

The CV08-20 allows flow passage from ① to ②, while normally blocking oil flow in the opposite direction.

The cartridge has a fully guided check which is spring-biased closed until sufficient pressure is applied at ① to open to ②.

FEATURES

- Hardened seat for long life and low leakage.
- Optional bias springs for back-pressure application flexibility.
- Fully guided check assembly.
- Compact size.
- Fast closing and seating.

RATINGS

Operating Pressure: 240 bar (3500 psi)

Proof Pressure: 350 bar (5075 psi)

Flow: See Performance Chart

Internal Leakage: 0.10 cc/minute (2 drops/minute) max. at 240 bar (3500 psi)

Crack Pressure Defined: Gauge psi evident at ① at 16.4 cc/minute (1 cu. in./minute) attained

Standard Bias Springs at Crack: 0.3 bar (4 psi); 0.7 bar (10 psi); 1.7 bar (25 psi); 4.1 bar (60 psi)

Temperature: -40 to 120°C

Filtration: See page 9.010.1

Fluids: Mineral-based or synthetics with lubricating properties at viscosities of 7.4 to 420 cSt (50 to 2000 ssu)

Installation: No restrictions; See page 9.020.1

Cavity: VC08-2; See page 9.108.1

Cavity Tool: CT08-2XX; See page 8.600.1

Seal Kit: SK08-2X-T; See page 8.650.1

SYMBOLS

USASI:

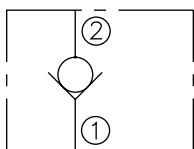

ISO:

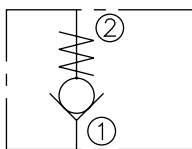

PERFORMANCE (Cartridge Only)

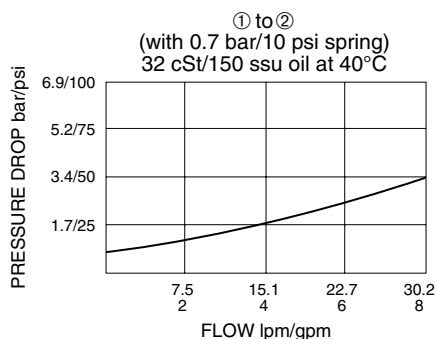

CV08-20

DIMENSIONS

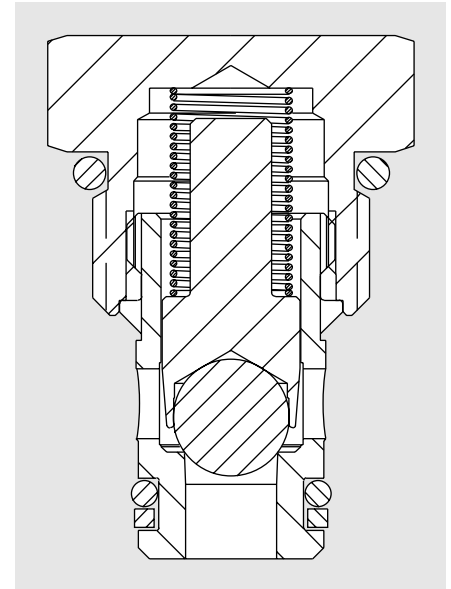
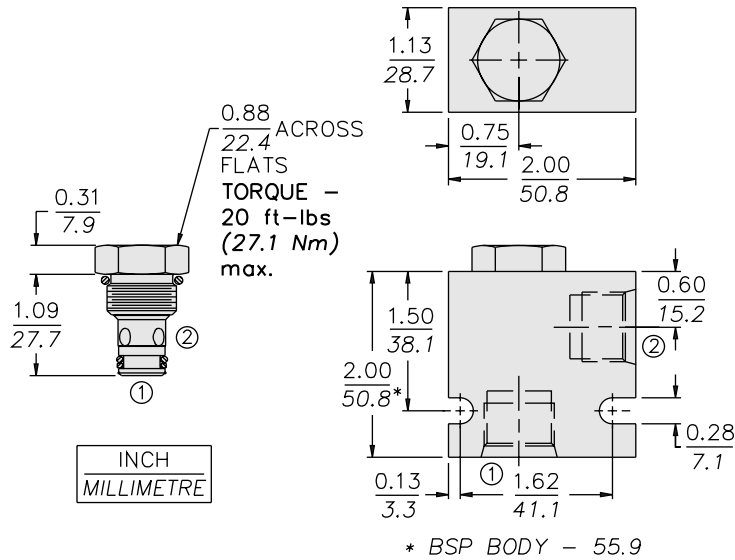

MATERIALS

Cartridge: Weight: 0.05 kg. (0.12 lbs.); Steel with hardened work surfaces; Zinc-plated exposed surfaces; Buna N O-rings and back-up standard.

Standard Ported Body: Weight: 0.16 kg. (0.35 lbs.); Anodized high-strength 6061 T6 aluminum alloy, rated to 240 bar (3500 psi); See page 8.008.1. Ductile iron and steel bodies available; consult factory.

TO ORDER

CV08-20 -

Porting
Cartridge Only **0**
SAE 4 **4T**
SAE 6 **6T**
SAE 8 **8T**
1/4 in. BSP* **2B**
3/8 in. BSP* **3B**
1/2 in. BSP* **4B**

*BSP Body;
U.K. Mfr. Only

Bias Spring

4 0.3 bar (4 psi)
10 0.7 bar (10 psi)
25 1.7 bar (25 psi)
60 4.1 bar (60 psi)
100 6.9 bar (100 psi)
150 10.3 bar (150 psi)
200 13.8 bar (200 psi)
270 18.3 bar (270 psi)

Seals

N Buna N (Std.)
V Fluorocarbon